

MOTION PLATFORM QS-220

800mm/s

MAXIMUM VELOCITY

100mm

ACTUATOR STROKE

1000Hz

MAXIMUM CONTROL FREQUENCY



0.8G

MAXIMUM ACCELERATION

<8ms

LATENCY

0-100Hz









VIBRATIONS FREQUENCY RANGE

MOTION PLATFORM QS-220



QS-220 patent pending technology of linear actuators allows to develop highly realistic applications with detailed motion textures, velocity, suspension interaction feedback, engine vibrations, tactile feedback, haptic system and vehicle dynamics.

Innovative technology, modular and compact design, as well as the quiet operation makes the QS-220 a perfect motion base not only for professional applications but also for home users in various types of cockpits. Additional sets of QS-220 can be configured as a 4 and 6 actuated system to provide 3 / 4 / 5 / 6 DOF using dedicated cockpits from Qubic System product line.

KEY FEATURES

 <p>Real-Time vibrations</p> <p>Generate precise real-time vibrations up to 100 Hz</p>	 <p>Compact design</p> <p>Small footprint and lightweight body</p>	 <p>Easy to deploy</p> <p>Predefined set of motion profiles for various actuators configurations</p>	 <p>Modular and Reconfigurable</p> <p>Possibility to expand the system up to 8 cooperating actuators.</p>
 <p>Wide range of motion</p> <p>Linear actuators with stroke up to 100 mm</p>	 <p>Super silent</p> <p>Extremely quiet and smooth operation</p>	 <p>Low power consumption</p> <p>High performance devices with minimal power budget</p>	 <p>Plug&Play</p> <p>Ready to work in a few minutes</p>

GENERAL SPECIFICATION

	Q-MODE 230V	PERFORMANCE MODE 115 / 230V	HEAVY DUTY MODE 115 / 230V
MAXIMUM VELOCITY	800 mm/s	400 mm/s	300 mm/s
MAXIMUM ACCELERATION	LIMITED TO 0,8G*	LIMITED TO 0,7G*	LIMITED TO 0,4G*
MAXIMUM PAYLOAD IN 3DOF**	200 kg	250 kg	350 kg
* value of acceleration is limited for safety reasons. ** configuration of 2 x QS-220.			
ARCHITECTURE	2 / 3 / 4 / 5 / 6 DOF (depending on user configuration and number of modules)		
ACTUATOR STROKE	100 mm 3,93 in		
MAXIMUM CONTROL FREQUENCY	1000 Hz		
VIBRATIONS FREQUENCY RANGE	0-100 Hz		
LATENCY	< 8 ms		
PRODUCT WEIGHT	30 kg 66 lb		
	QS-L1 ACTUATOR	QS-SB2 POWER CABINET	
TOTAL LENGTH	106 mm 4.17 in	355 mm 15.16 in	
TOTAL WIDTH	92 mm 3.62 in	300 mm 11.81 in	
TOTAL HEIGHT	560-660 mm 22-26 in	92 mm 3.62 in	
CABLE LENGTH (QS-L1 actuator - QS-SB2 Power cabinet)	1150 mm 45,2 in		
POWER SUPPLY REQUIREMENTS	115 / 230 VAC Single Phase		
CONNECTION	USB		
CONFORMITY INFORMATION	 		

POWER REQUIREMENTS IN 3DOF CONFIGURATION (2 x QS-220)

	Q-MODE 230V	PERFORMANCE MODE 110 / 230V	HEAVY DUTY MODE 110 / 230V
AVERAGE POWER [kVA]	1.2	0.7 / 0.9	0.7 / 0.7
PEAK POWER [kVA]	2.2	1.5 / 1.6	1.5 / 1.5
PEAK CURRENT [A]	10	13 / 7	12 / 7
AVERAGE POWER (STRESS TEST) [kW]	0.5	0.3 / 0.3	0.3 / 0.3
AVERAGE POWER (TYPICAL GAME) [kW]	0.03	0.05 / 0.04	0.06 / 0.07

QS-220 MOTION SET

QS-L1	2 pieces of linear actuators with stabilization plates
QS-SB2	1 pcs of power cabinet (control module)
QS-SBML-2	1 pcs of motion lock cable (up-link/down-link) - 2 meters long
Power cable	1 pcs of 1,8 m long cable for EU market / or 1 pcs of 2 m long cable for USA market

QS-MC6 MOTION CONTROLLER SET

M10	1 pcs of USB controller
QS-SBML-1	1 pcs of motion lock with additional 2 m long cable
QS-MBT-1	1 pcs of M-BUS terminator
USB cable	1 pcs of 0,5 m long cable (USB micro B)
CAT.5E patch cord cable	1 pcs of 2 m long cable

OUR SOFTWARE

Qubic Manager (free-of-charge license included) | Motion SDK - ForceSeatDI | Motions SDK - ForceSeatMI | Motion Theater

QS-L1 ACTUATOR GENERAL DIMENSIONS

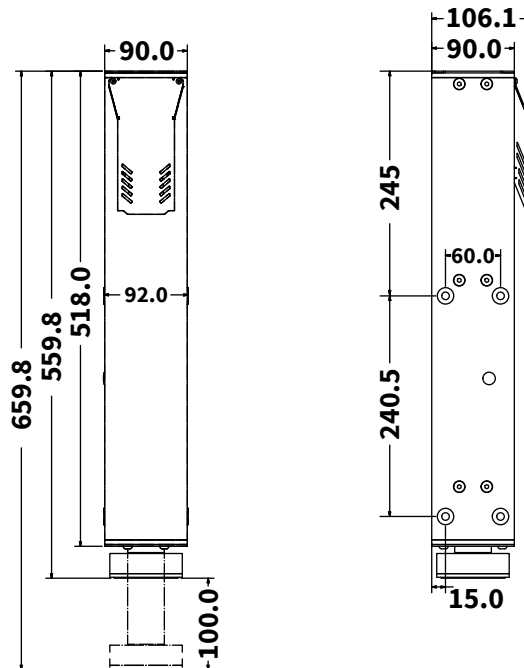

QS-SB2 POWER CABINET **GENERAL DIMENSIONS**

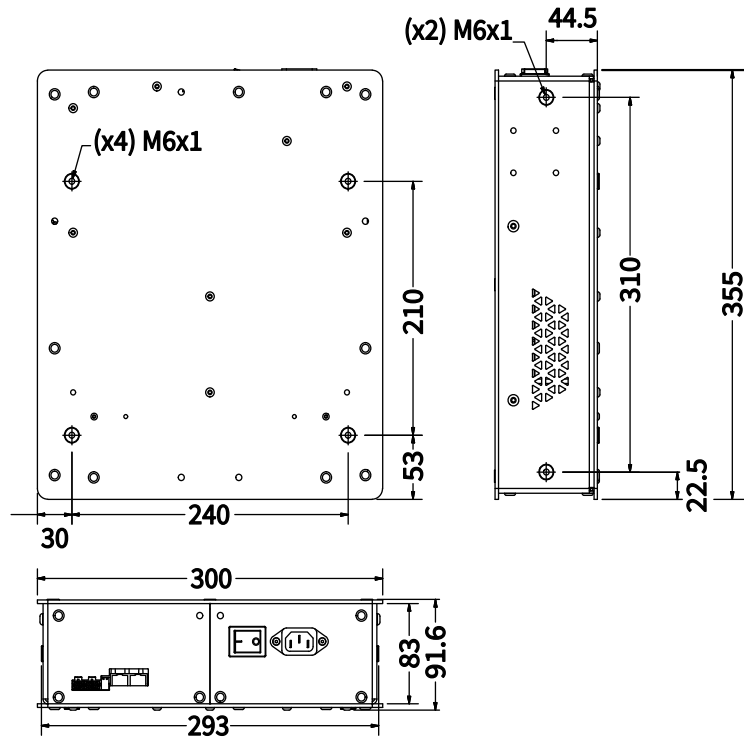

QS-BRACKETS **GENERAL DIMENSIONS**

